

LOC	DIST	REVISIONS			
P	LTR	DESCRIPTION	DATE	DWN	APVD
GP	00	A1	REVISED PER ECO-11-004835	11MAR11	RK HMR

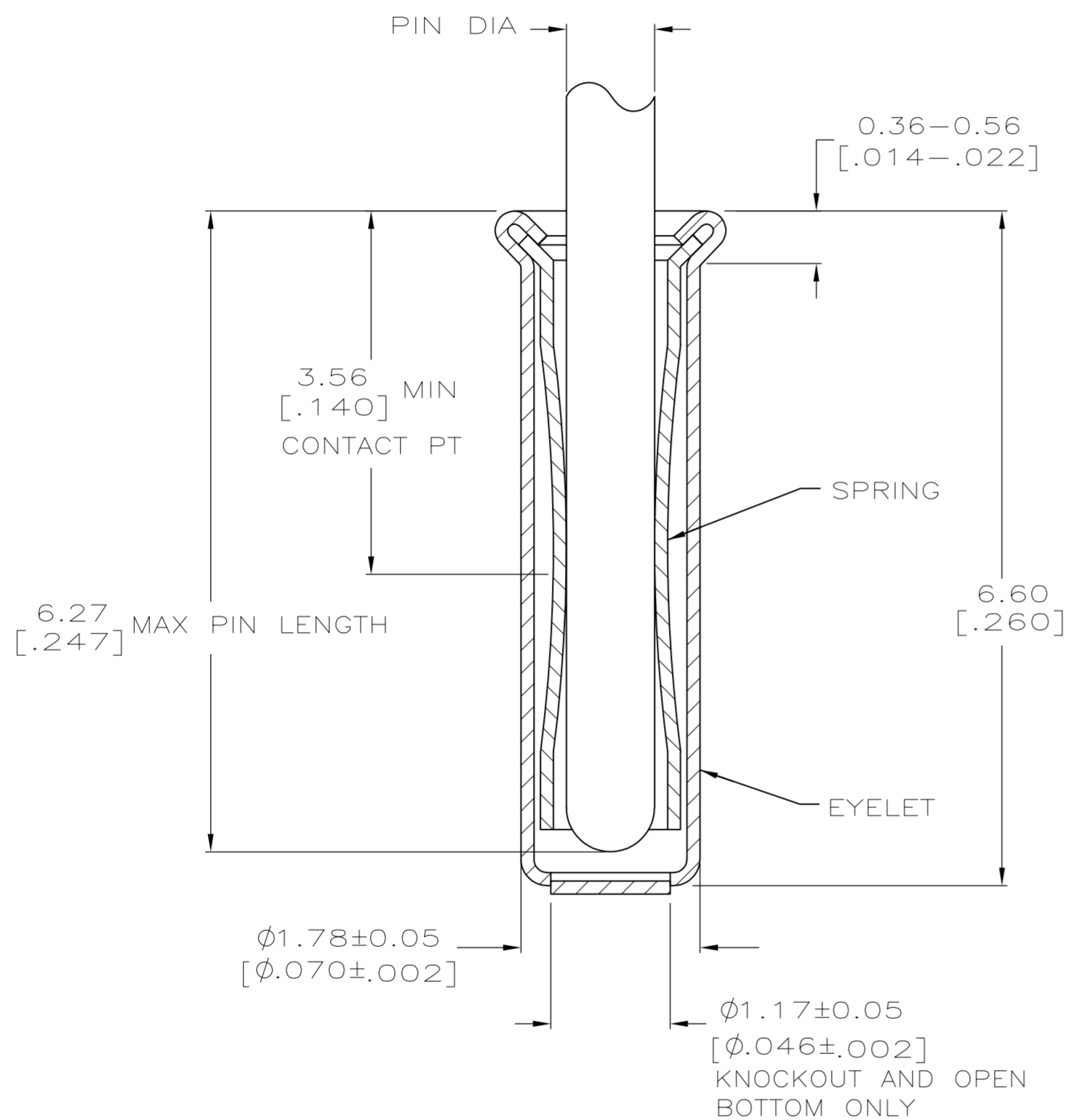
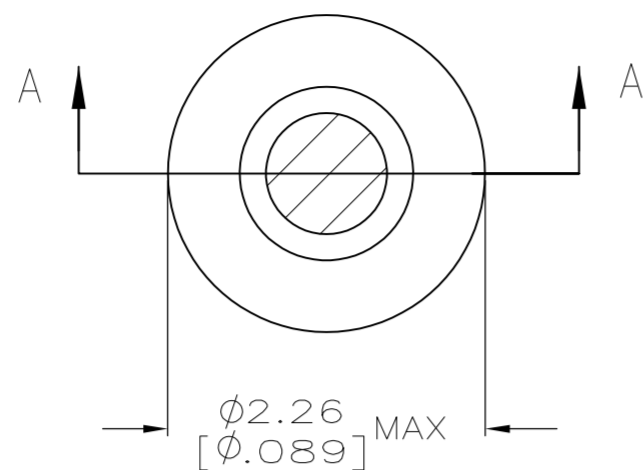

SECTION A-A

1. TIN PLATE PER ASTM-B-545 .000254 [.000100] MINIMUM THICK.
2. NICKEL UNDERPLATE ALL OVER, MATING SURFACE PLATED TO MEET PERFORMANCE REQUIREMENTS OF TE CONNECTIVITY PRODUCT SPECIFICATION 108-14008.
3. RECOMMENDED HOLE SIZE, PLATED OR UNPLATED:
 MACHINE INSERTION: $1.83 \begin{matrix} +0.10 \\ -0.08 \end{matrix} \begin{matrix} [.072 \text{ } +.004 \\ \text{ } -.003] \end{matrix}$
 HAND INSERTION: $1.83 \begin{matrix} +0.10 \\ -0.00 \end{matrix} \begin{matrix} [.072 \text{ } +.004 \\ \text{ } -.000] \end{matrix}$
4. APPLICATION TOOL PART NUMBER:
 MACHINE NO. 682127-5
 INSERTION HEAD NO. 682039-4
5. TO INSURE PROPER SPRING TENSION DO NOT EXCEED A 0.05 [.002] DIFFERENCE IN PIN DIA WHEN CHANGING TO A SMALLER PIN.
6. BOTTOM PLUG KNOCKOUT TOOL PART NUMBER 69729 WITH TIP PART NUMBER 69728-2.
7. MATERIAL: SPRING: BERYLLIUM COPPER QQ-C-533
 EYELET: COPPER, QQ-C-576

CLOSED	0.86-1.04 [.034-.041]	TIN $\triangle 1$	TIN $\triangle 1$	5050865-8
KNOCKOUT			GOLD $\triangle 2$	5050865-7
OPEN				5050865-6
CLOSED				5050865-5
OPEN				5050865-3
KNOCKOUT				5050865-1
BOTTOM TYPE	RECOMMENDED PIN DIA $\triangle 5$	EYELET	SPRING	PART NO
FINISH				

THIS DRAWING IS A CONTROLLED DOCUMENT.		DWN J. ALCORTA - DOCK5 20APR2005	TE Connectivity	
DIMENSIONS: mm [INCHES]		CHK J. HAVENER 25JUL2005	MINIATURE SPRING SOCKET ASSEMBLY SERIES 4	
TOLERANCES UNLESS OTHERWISE SPECIFIED:		APVD J. HAVENER 25JUL2005	NAME	RESTRICTED TO
0 PLC	± -	PRODUCT SPEC	108-14008	
1 PLC	± -	APPLICATION SPEC	114-13152	
2 PLC	± -	WEIGHT	-	
3 PLC	± 0.20 [.008]	SIZE	A2	
4 PLC	± -	CAGE CODE	00779	
ANGLES	± -	DRAWING NO	C=5050865	
MATERIAL	FINISH	CUSTOMER DRAWING	SCALE 20:1	SHEET 1 of 1
	SEE TABLE		REV A1	